

DSC STUDIES ON THE THERMAL STABILITY OF BIS[4-(4'-ETHYNYLPHENOXY)PHENYL] SULFONE AND BIS[4-(4'-ETHYNYLPHENOXY)PHENYL] KETONE *

LIU ZHENHAI, YANG ZHENJIANG, ZHANG ZEYI, CHEN ZHONGQING
and FU GUOZHEN

*Changchun Institute of Applied Chemistry, Academia Sinica, Changchun,
Jilin (People's Republic of China)*

(Received 3 February 1987)

ABSTRACT

DSC studies on the thermal polymerization of bis[4-(4'-ethynylphenoxy)phenyl] sulfone (K_s) and bis[4-(4'-ethynylphenoxy)phenyl] ketone (K_c) show that the temperature range for the thermal polymerization for this kind of monomer is 155–327°C, depending on the chemical structure of the monomer. The apparent activation energies of thermal polymerization of the K_s , K_c and K_f monomers were obtained from DSC measurements as 65.1, 76.2 and 83.1 kJ mol⁻¹, respectively. The thermal stabilities of these monomers at room temperature were predicted on the basis of kinetic analysis.

INTRODUCTION

The polymers of bis[4-(4'-ethynylphenoxy)phenyl] sulfone and bis[4-(4'-ethynylphenoxy)phenyl] ketone have excellent heat- and moisture-resistant properties and may be used as heat resistant adhesives for composite materials. Because the structure of this kind of monomer contains acetylenic end-groups, it is necessary to determine the rate of thermal polymerization of the monomer at various temperatures in order to predict the stability of the monomer at room temperature. Pickard et al. [1] and Cotts and Berry [2] have reported details of the thermal polymerization kinetics of acetylenic end-group monomers.

* Paper presented at the Sino-Japanese Joint Symposium on Calorimetry and Thermal Analysis, Hangzhou, People's Republic of China, 5–7 November 1986.

EXPERIMENTAL

For the thermal stability studies, the exothermic effect was determined from isothermal and dynamic DSC measurements using a CDR-1 differential scanning calorimeter (Shanghai Tienping Instrument Factory, China). The apparatus was calibrated with indium. A sample of 10.0 mg was used at a heating rate of $10^{\circ}\text{C min}^{-1}$. The DSC scale was $\pm 5 \text{ mcal s}^{-1}$. In isothermal experiments, a sample of monomer was weighed into a DSC pan and heated to the desired temperature at a heating rate of $10^{\circ}\text{C min}^{-1}$. At periodic intervals, the sample treated isothermally was cooled to below 75°C and rescanned at the same heating rate. All experiments were conducted under a nitrogen atmosphere at a controlled rate of 100 ml min^{-1} .

Additional isothermal experiments were conducted by monitoring the change in IR spectra using a Perkin-Elmer 599 B spectrophotometer.

RESULTS AND DISCUSSION

The chemical structures of the acetylenic monomers used in the present work are shown in Scheme 1.

Figure 1 illustrates the reaction exotherms obtained from the dynamic DSC experiments for all six samples. From the DSC curves, it can be seen

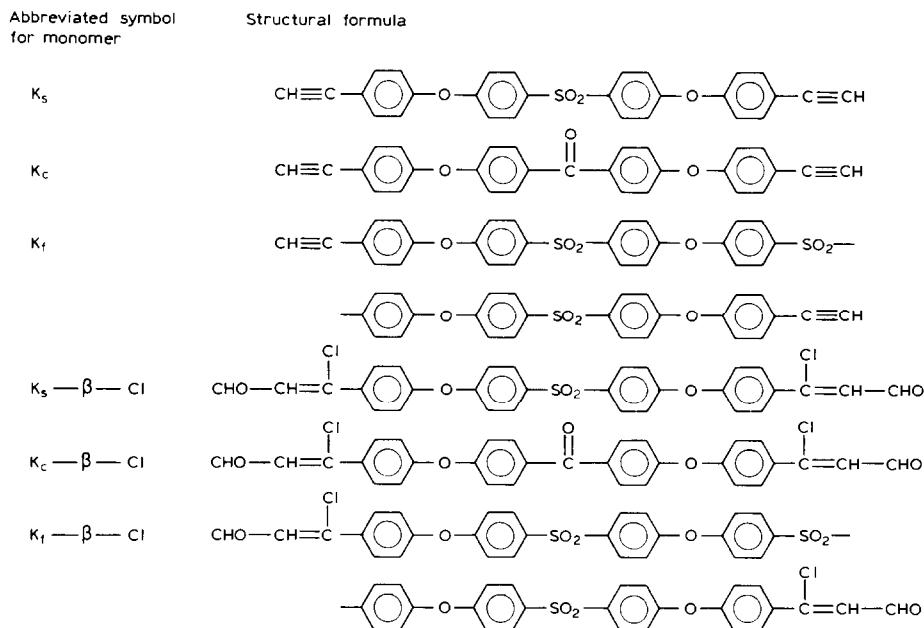

Scheme 1.

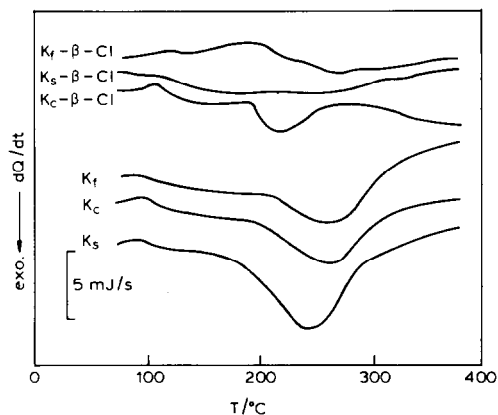

Fig. 1. DSC curves of K_s , K_c , K_f , K_s - β -Cl, K_c - β -Cl and K_f β -Cl.

that the reaction temperature ranges for K_s , K_c and K_f are 155–325, 175–325 and 190–327.5°C, respectively. For the samples treated isothermally at lower temperatures for several hours, for example 80°C and 100 min, there appeared a characteristic absorption peak at 1660 cm^{-1} in the IR spectrum, indicating the generation of a double bond from the acetylenic end-group (see Fig. 2).

The change in the DSC curves of the samples treated isothermally can be used as a measure of thermal polymerization or thermal stability. Figure 3 shows the DSC curves of samples treated at various temperatures for 1 h. From these data the temperature dependence of the thermal polymerization rates of the monomers could be obtained (Fig. 4); S_0 and S represent the peak areas in the DSC curves of original and treated samples, respectively. For samples treated at a variety of temperatures and periods, similar results

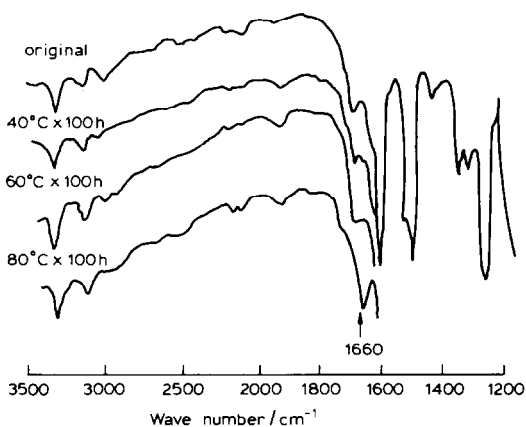

Fig. 2. IR spectra of K_s samples, original and treated at 40, 60, 80°C for 100 h.

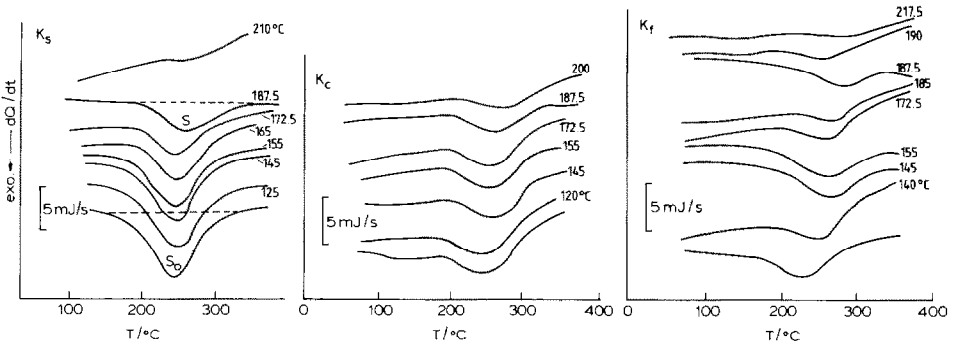

Fig. 3. DSC curves of K_s , K_c and K_f samples treated at various temperatures for 1 h.

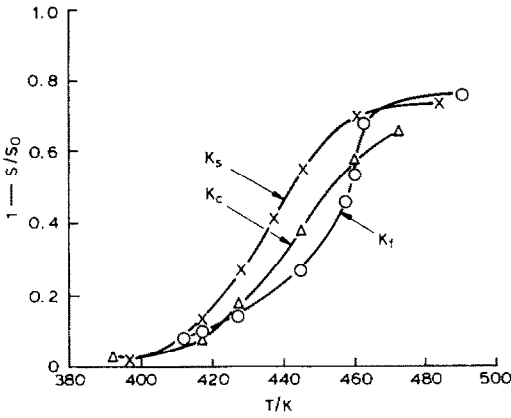

Fig. 4. Temperature dependence of the thermal polymerization conversion of monomers K_s , K_c and K_f .

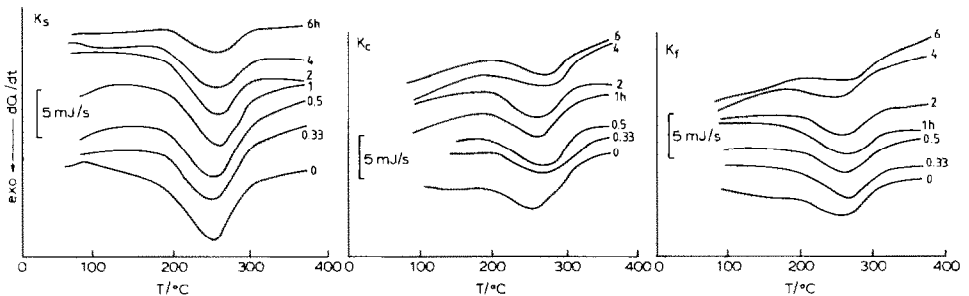

Fig. 5. DSC curves of K_s , K_c and K_f samples treated at 155°C for periodic intervals.

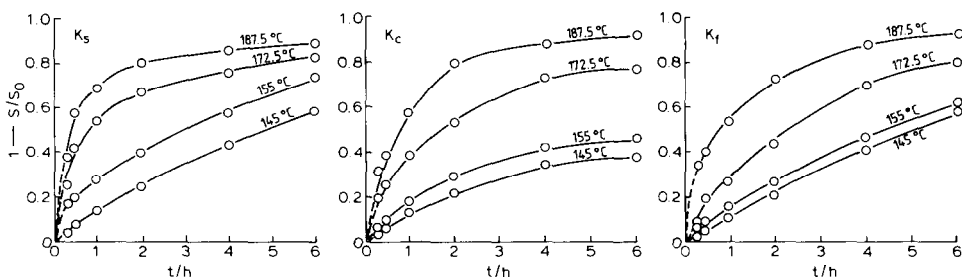

Fig. 6. Thermal polymerization conversion of K_s , K_c and K_f at various temperatures.

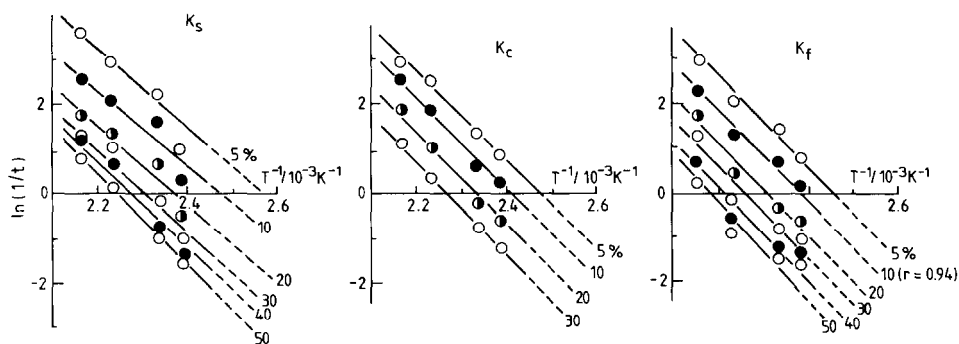

Fig. 7. Arrhenius plot for the conversion of K_s , K_c and K_f (from the data of Fig. 6).

were obtained (see Figs. 5 and 6). An Arrhenius plot of the thermal polymerization rate based on data of Fig. 6 is shown in Fig. 7. In this way, the apparent activation energies 65.1 , 76.2 and 83.1 kJ mol^{-1} are calculated from the isothermal experimental data for K_s , K_c and K_f , respectively. The thermal stability decreases in the order $K_f > K_c > K_s$. The greater stability of K_f may be due to the smaller percentage of acetylenic group in the monomer. The polar sulfone group plays a fairly active role in the reaction of the K_s monomer, so that K_s is less stable than K_c .

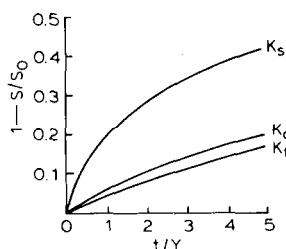

Fig. 8. Conversion vs. time plots extrapolated to room temperature from the data of Fig. 7 for the thermal polymerization of K_s , K_c and K_f .

The results in Fig. 7 were extrapolated to room temperature for various levels of conversion, resulting in the plots in Fig. 8, from which the reaction rates of the monomers at room temperature may be predicted. For example, the amounts of reacted monomer at 25°C after 1 year are 20, 6 and 4% for K_s , K_c and K_f , respectively.

REFERENCES

- 1 J.M. Pickard, E.G. Jones and I.J. Goldfarb, *Polym. Prepr., Am. Chem. Soc. Div. Polym. Chem.*, 19(2) (1978) 591.
- 2 D.B. Cotts and G.C. Berry, *Polym. Prepr., Am. Chem. Soc. Div. Polym. Chem.*, 20(2) (1979) 570.
- 3 Zhang Zeyi, Mu Bilu, Chu Youdong, Yuan Yagui and Liu Kejing, *Collect. Pap. Changchun Inst. Appl. Chem., Acad. Sin.*, 18 (1982) 142.